



## REGULAR CITY COUNCIL MEETING

May 17, 2022 at 5:30 PM

Council Meeting Room, 101 North State Street,  
Abbeville, Louisiana 70510

---

### AGENDA

**NOTICE POSTED: May 16, 2022 at 4:00 P.M.**

#### REGULAR ORDER OF BUSINESS

Call to Order by Mayor  
Roll Call by Kathy Faulk  
Prayer  
Pledge

#### PERSONNEL

#### MINUTES AND APPROVAL OF BILLS

1. Ratify bills paid in the month of April 2022.

#### PUBLIC COMMENTS

(To allow comments on any of the following items prior to action.)

#### NEW BUSINESS

1. Contract for proposal to perform emergency debris removal related to a disaster for 2022-2023-Richard Primeaux.
2. Contract for professional engineering services in connection with emergency recovery events for 2022-2023-Richard Primeaux
3. To discuss responses from request for proposals for electrical and food services after disasters and to act on the proposals received.
4. To adopt a resolution authorizing requesting financial assistance through the Delta Regional Authority (DRA) for the States' Economic Development Assistance Program and grant authorization to Sellers and Associates, Inc. to prepare said application and and the Mayor to sign all necessary documentation for the grant application.
5. To approve payment of three invoices from Event Solutions totaling \$15,335.00 for monthly rentals of a restroom trailer from 3/10/22 through 6/2/22 and one invoice in the amount of \$485.00 for restroom trailer cleaning and a port-a-let and to decide where to pay the invoices from.
6. To adopt a resolution authorizing the Mayor to execute agreements with DOTD and FAA and to award and sign related contracts for the FY 2022 projects at the Chris Crusta Memorial Airport.
7. Approval to use the 2021-2022 Local Government Assistance Program (LGAP) grant in the amount of \$20,000.00 to purchase a portable diesel air compressor and to use the 2021-2022 Community Water Enrichment Program (CWEF) grant in the amount of \$20,000.00 to purchase, fittings, clamps, valves, meter, piping and other miscellaneous items needed to repair leaking water lines.
8. To approve the purchase of fire hydrants from Coburn's in the amount of \$27,833.82.
9. To approve the quote from Bihm Construction in the amount of \$25,000.00 to replace the backflow preventer at the Wastewater Treatment Plant.
10. To approve the quote from Griffin Filter Technologies, Inc in the amount of \$8,850.00 for materials and the quote in the amount \$7,050.00 from MMR for the labor and installation to remove the old lime dust collection and install a new lime dust collector at the Wastewater Plant.

#### OLD BUSINESS

1. None.

#### TOPICS FOR DISCUSSION

1. Council Members

#### ADJOURN

In accordance with the Americans with Disabilities Act,  
if you need special assistance, please contact  
Mayor Mark Piazza's office at 337-893-8550,  
describing the assistance that is necessary.

**CHECK**

**REGISTERS**

**ALL FUNDS**

**APRIL 2022**

ACCOUNTS PAYABLE CHECK REGISTER

CHECK NO.	DATE	VENDOR NAME	CHECK AMOUNT
77025	4/07/22	TRUMAN ABSHIRE BODY	60.00
77026	4/07/22	AUTOMATION SERVICE & CONTROLS	400.00
77027	4/07/22	NORRIS BAUDOIN	280.00
77028	4/07/22	BAYOU FENCING AND SUPPLY INC	23,067.56
77029	4/07/22	BROUSSARD PEST CONTROL	225.00
77030	4/07/22	CAPITAL ELECTRIC & SUPPLY, LLC	1,011.50
77031	4/07/22	CHAMPAGNES OF ABBEVILLE	67.94
77032	4/07/22	COMMITTEE OF CERTIFICATION	30.00
77033	4/07/22	NOVATECH, INC	75.54
77034	4/07/22	CNH INDUSTRIAL RETAIL ACCTS	1,311.82
77035	4/07/22	COX BUSINESS	1,604.69
77036	4/07/22	CENTER FOR WORK REHAB INC	370.00
77037	4/07/22	DEHART SHIPYARD INC	173.50
77038	4/07/22	DON'S LAWN SERVICE	10,708.33
77039	4/07/22	DUHON'S MOBILE OIL SERVICES	200.00
77040	4/07/22	CENTERPOINT ENERGY	952.93
77041	4/07/22	EVENT SOLUTIONS	650.00
77042	4/07/22	EVANGELINE SPECIALTIES INC	638.96
77043	4/07/22	ANN HARDY	93.24
77044	4/07/22	MAGNOLIA PLANTATION WATER	20.38
77045	4/07/22	MELLO JOY COFFEE CO LLC	77.90
77046	4/07/22	KAPTEL	119.40
77047	4/07/22	MYRA'S LAWN SERVICE	2,400.00
77048	4/07/22	PRO-INK CUSTOMS, LLC	354.00
77049	4/07/22	MYLES HUTCHINSON	300.00
77050	4/07/22	RAY CHEVROLET- OLD, INC	121.21
77051	4/07/22	SOUTHERN SCREEN & DYE INC	1,050.00
77052	4/07/22	STURDI STEEL	113,755.00
77053	4/07/22	FELICIA THIBEAUX	385.00
77054	4/07/22	THRIFTY WAY PHARMACY INC	45.00
77055	4/07/22	TICKETS SERVICE, LLC	1,600.00
77056	4/07/22	UTILITY BILLS	12,928.53
77057	4/07/22	UTILITY BILLS	1,217.34
77058	4/07/22	VERIZON WIRELESS (POLICE)	2,332.96
77059	4/07/22	VERMILION SHELL CO INC	7,132.03
		TOTALS	185,759.76



ACCOUNTS PAYABLE CHECK REGISTER

CHECK NO.	DATE	VENDOR NAME	CHECK AMOUNT
77060	4/08/22	EMPLOYEE HEALTH INSURANCE	81,832.76
		TOTALS	81,832.76

1  
2  
3  
4  
5  
6  
7  
8  
9  
10  
11  
12  
13  
14  
15  
16  
17  
18  
19  
20  
21  
22  
23  
24  
25  
26  
27  
28  
29  
30  
31  
32  
33  
34  
35  
36  
37  
38  
39  
40  
41  
42  
43  
44  
45  
46  
47  
48  
49  
50  
51  
52  
53  
54  
55  
56  
57

Jan Dec 0 10:43:53

ACCOUNTS PAYABLE CHECK REGISTER

CK

	DATE	VENDOR NAME	CHECK AMOUNT
51	4/14/22	BIHMCO	4,600.00
52	4/14/22	COPY SERVICES BY ALICE LLC DBA	90.00
53	4/14/22	COX BUSINESS	95.04
54	4/14/22	ENTERGY	1,608.59
55	4/14/22	LOWES BUSINESS ACCOUNT	2,848.09
56	4/14/22	NAV-TEL SERVICES, LLC	950.00
57	4/14/22	O'REILLY AUTOMOTIVE INC	693.42
58	4/14/22	S L E M C O	144.86
59	4/14/22	SPRACO INC	14,657.00
70	4/14/22	UTILITY BILLS	11,184.54
71	4/14/22	UTILITY BILLS	1,019.88
72	4/14/22	UTILITY BILLS	6,707.37
73	4/14/22	UTILITY BILLS	1,906.30
74	4/14/22	UTILITY BILLS	446.59
75	4/14/22	VERIZON WIRELESS	1,438.86
76	4/14/22	VERIZON BUSINESS	52.99
77	4/14/22	HANCOCK WHITNEY BANK	5,267.83
		TOTALS	53,711.36



ACCOUNTS PAYABLE CHECK REGISTER

CHECK NO.	DATE	VENDOR NAME	CHECK AMOUNT
1 77078	4/19/22	ABBEVILLE ELECTRIC SUPPLY INC	6,072.86
2 77079	4/19/22	ABBEVILLE GENERAL HOSPITAL	900.00
3 77080	4/19/22	ABBEVILLE MERIDIONAL INC	3,244.60
4 77081	4/19/22	ABBEVILLE MERIDIONAL INC	631.20
5 77082	4/19/22	ABBEVILLE MOBILE GLASS, LLC	220.00
6 77083	4/19/22	TRUMAN ABSHIRE BODY	264.89
7 77084	4/19/22	ACADIANA SHELL INC	642.69
8 77085	4/19/22	ACTION SPECIALITIES LLC	1,030.40
9 77086	4/19/22	ADVANCE CHEMICAL SUPPLY INC	6,133.00
10 77087	4/19/22	ALLUME' SOCIETY	85.00
11 77088	4/19/22	ANTHEM SPORTS, LLC	1,089.95
12 77089	4/19/22	ARC OF ACADIANA	150.00
13 77090	4/19/22	BARNEY'S POLICE SUPPLIES	124.95
14 77091	4/19/22	COURTESY FORD SOUTH	3,628.51
15 77092	4/19/22	BAYOU ELECTRIC & SPECIALTY INC	128.22
16 77093	4/19/22	FLOYD'S SERVICE STATION	50.00
17 77094	4/19/22	BRASSEUX'S HARDWARE	423.86
18 77095	4/19/22	BRASSEUX'S HARDWARE	324.87
19 77096	4/19/22	BRASSEUX'S HARDWARE	421.92
20 77097	4/19/22	BRASSEUX'S HARDWARE	360.73
21 77098	4/19/22	BRASSEUX'S OUTDOOR	1,392.61
22 77099	4/19/22	CAPITAL ELECTRIC & SUPPLY, LLC	7,825.00
23 77100	4/19/22	CLERK OF COURT	1,616.00
24 77101	4/19/22	COMMUNITY COFFEE SERVICE CO	289.25
25 77102	4/19/22	CONTROL DEVICES INC	1,105.00
26 77103	4/19/22	CRAIG HEBERT'S TEXACO	40.00
27 77104	4/19/22	CINTAS CORPORATION LOC 543	5,229.37
28 77105	4/19/22	CUSTOM ENVIRONMENTAL	2,415.17
29 77106	4/19/22	CUSTOM GLASS & MIRROR, INC	468.85
30 77107	4/19/22	DISCOUNT TIRE CENTER INC	45.90
31 77108	4/19/22	DOUBLE W HOME & RANCH	6,764.22
32 77109	4/19/22	DPC ENTERPRISES, L.P.	200.00
33 77110	4/19/22	DATA SUPPORT CO. INC	400.00
34 77111	4/19/22	DUHON BROS OIL CO INC	26,094.36
35 77112	4/19/22	ESOFT PLANNER INC	775.00
36 77113	4/19/22	ELECTRONIC PROTECTION SYSTEMS	312.00
37 77114	4/19/22	EAGLE PEST CONTROL	345.00
38 77115	4/19/22	CENTERPOINT ENERGY	106.15
39 77116	4/19/22	F & R AIR CONDITIONING INC	531.22
40 77117	4/19/22	FLEURIET AUTOMOTIVE SERVICE	2,647.60
41 77118	4/19/22	GUIDRY'S UNIFORM INC	506.05
42 77119	4/19/22	AROSS BROWN	175.00
43 77120	4/19/22	IPFS CORPORATION	16,911.23
44 77121	4/19/22	INTEGRITY SUPPLY, LLC	765.69
45 77122	4/19/22	ABBEVILLE SNAPPER SALES	4,610.37
46 77123	4/19/22	JIM'S TIRE SERVICE INC	210.00
47 77124	4/19/22	K & J SUPPLIES, LLC	203.40
48 77125	4/19/22	KAPTEL	5,287.77
49 77126	4/19/22	LA MUNICIPAL RISK MGMT AGENCY	18,567.13
50 77127	4/19/22	LET US ANSWER	361.56
51 77128	4/19/22	LIFELINE	46.71
52 77129	4/19/22	LOUISIANA ONE CALL, INC	241.30
53 77130	4/19/22	L W C C	36,808.79



ACCOUNTS PAYABLE CHECK REGISTER

CHECK NO.	DATE	VENDOR NAME	CHECK AMOUNT
77131	4/19/22	MELLO JOY COFFEE CO LLC	87.34
77132	4/19/22	MMR GROUP, INC.	119.89
77133	4/19/22	NAT'L WELDING SUPPLY INC	130.23
77134	4/19/22	OFFICE MART	571.97
77135	4/19/22	OFFICE MART	338.93
77136	4/19/22	NU-TEK CAR SERVICE CENTER, INC	785.39
77137	4/19/22	PEREGRINE CORP. BUSINESS PRO	1,239.38
77138	4/19/22	PIAZZA OFFICE SUPPLY	95.98
77139	4/19/22	PITT STOP 9 MIN OIL CHANGE	271.80
77140	4/19/22	PUPIE'S AUTO REPAIR	1,014.04
77141	4/19/22	MYLES HUTCHINSON	200.00
77142	4/19/22	RAY CHEVROLET- OLD, INC	175.93
77143	4/19/22	REPUBLIC WHOLESALE CO INC	728.50
77144	4/19/22	S & V SERVICE, LLC	2,140.00
77145	4/19/22	SIRCHIE ACQUISITION CO LLC	171.78
77146	4/19/22	SPARTAN SERVICES GROUP, LLC	680.00
77147	4/19/22	SPECIAL T ICE COMPANY INC	66.50
77148	4/19/22	SPECIALTY CARTS	310.00
77149	4/19/22	TECHLINE LTD	8,002.00
77150	4/19/22	TERRY'S DIESEL REPAIR & SALES	1,037.81
77151	4/19/22	THOMSON REUTERS WEST	524.70
77152	4/19/22	THOMSON SMITH & LEACH	20.00
77153	4/19/22	NI WELDING SUPPLY, LLC	39.01
77154	4/19/22	UBED LLC	138.06
77155	4/19/22	VERMILION JANITORIAL &	1,391.05
77156	4/19/22	WASTE CONNECTIONS BAYOU, INC	393.52
		TOTALS	189,899.16



ACCOUNTS PAYABLE CHECK REGISTER

CHECK NO.	DATE	VENDOR NAME	CHECK AMOUNT
77157	4/21/22	EMPLOYEE HEALTH INSURANCE	88,246.44
77158	4/21/22	AMERICAN WATER WORKS ASSOC	389.00
77159	4/21/22	DELTA FIRE AND SAFETY	8,522.29
77160	4/21/22	LUKE DESHOTELS CONSTRUCTION	1,600.00
77161	4/21/22	S P I MUNICIPAL SUPPLY INC	29,821.95
77162	4/21/22	VERMILION JANITORIAL &	575.60
77163	4/21/22	WECHEM, INC	1,383.40
TOTALS			130,538.68

1  
2  
3  
4  
5  
6  
7  
8  
9  
10  
11  
12  
13  
14  
15  
16  
17  
18  
19  
20  
21  
22  
23  
24  
25  
26  
27  
28  
29  
30  
31  
32  
33  
34  
35  
36  
37  
38  
39  
40  
41  
42  
43  
44  
45  
46  
47  
48  
49  
50  
51  
52  
53  
54  
55  
56  
57



## ACCOUNTS PAYABLE CHECK REGISTER

APGL16 PAGE

CHECK NO.	DATE	VENDOR NAME	CHECK AMOUNT	
1	77164	4/28/22	ABBEVILLE GENERAL HOSPITAL	75.00
2	77165	4/28/22	THE ABDA GROUP	1,500.63
3	77166	4/28/22	ADVANCE CHEMICAL SUPPLY INC	714.10
4	77167	4/28/22	ARSEMENT & HAYES, LLC	1,788.75
5	77168	4/28/22	AT&T	35.82
6	77169	4/28/22	AT&T	99.43
7	77170	4/28/22	AUTOMATION SERVICE & CONTROLS	400.00
8	77171	4/28/22	BAYDU FENCING AND SUPPLY INC	38,942.67
9	77172	4/28/22	COMTECH SYSTEMS OF LA, LLC	600.00
10	77173	4/28/22	COMMUNITY COFFEE SERVICE CO	154.35
11	77174	4/28/22	CMA	2,568.75
12	77175	4/28/22	COX BUSINESS	502.50
13	77176	4/28/22	CUSTOM ENVIRONMENTAL	2,782.17
14	77177	4/28/22	D V L ELECTRIC WORKS INC	6,770.77
15	77178	4/28/22	CENTERPOINT ENERGY	347.11
16	77179	4/28/22	EVANGELINE SPECIALTIES INC	1,660.45
17	77180	4/28/22	F & R AIR CONDITIONING INC	166.00
18	77181	4/28/22	FBAC FONTENOT BENEFITS &	2,250.00
19	77182	4/28/22	GASPARD AUTO REPAIR & WRECKER	380.00
20	77183	4/28/22	GRINER DRILLING SERVICE INC	14,155.60
21	77184	4/28/22	GULF STATES DISTRIBUTORS	3,580.00
22	77185	4/28/22	HERCULES LOCK	32.02
23	77186	4/28/22	HIDCO	1,882.10
24	77187	4/28/22	HO-PAK LABORATORY INC	887.00
25	77188	4/28/22	HO-PAK LTD.	379.00
26	77189	4/28/22	ABBEVILLE SNAPPER SALES	130.00
27	77190	4/28/22	WINSUPPLY	7,235.69
28	77191	4/28/22	MCNEILUS FINANCIAL, INC.	579.49
29	77192	4/28/22	MEDXCEL OCCUPATIONAL MEDICINE	584.50
30	77193	4/28/22	MELE PRINTING COMPANY, LLC	4,092.76
31	77194	4/28/22	MELLO JOY COFFEE CO LLC	6.45
32	77195	4/28/22	MINVIELLE LUMBER CO INC	302.78
33	77196	4/28/22	MOBILE MONITORING	322.81
34	77197	4/28/22	MUSIC MOUNTAIN	9.00
35	77198	4/28/22	PELLERIN & WALLACE INC	1,109.00
36	77199	4/28/22	RAY CHEVROLET- OLD, INC	1,513.10
37	77200	4/28/22	REPUBLIC WHOLESALE CO INC	397.96
38	77201	4/28/22	SELLERS & ASSOC INC	20,018.15
39	77202	4/28/22	SHARP ELECTRONICS CORPORATION	343.40
40	77203	4/28/22	S L E M C O	390.00
41	77204	4/28/22	S P I MUNICIPAL SUPPLY INC	9,978.65
42	77205	4/28/22	SUPERIOR RESOURCES LLC	3,261.10
43	77206	4/28/22	TECHLINE LTD	32,828.87
44	77207	4/28/22	TERRY'S DIESEL REPAIR & SALES	2,168.36
45	77208	4/28/22	THIBODEAUX TOWN & COUNTRY	2,676.19
46	77209	4/28/22	TOSHIBA FINANCIAL SERVICES	306.63
47	77210	4/28/22	U S A BLUE BOOK	320.90
48	77211	4/28/22	VERMILION JANITORIAL &	606.50
49	77212	4/28/22	WALMART COMMUNITY CARD	1,135.92
50	77213	4/28/22	WECHEM, INC	1,135.90
51			TOTALS	174,108.33
52				
53				
54				
55				
56				
57				



CHECK NO.	DATE	G/L DESCRIPTION	CHECK AMOUNT
1			
2	29475	4/01/22 LAURA FREDERICK	391.66
3	29485	4/01/22 PARK & RECREATION FUND	8,334.00
4	29486	4/01/22 VERMILION PARISH SHERIF	8,750.00
5	29487	4/01/22 RANDALL ABSHIRE	1,000.00
6	29488	4/01/22 PUBLIC IMPROVEMENT FUND	8.75
7	29489	4/04/22 JACOB DUPONT	21.88
8	29490	4/04/22 LOUISIANA MUNICIPAL ASS	180.00
9	29491	4/05/22 MARK PIAZZA	27.77
10	29492	4/05/22 SPOTLESS CLEANING SYSTE	1,400.00
11	29493	4/05/22 PUBLIC IMPROVEMENT FUND	16.96
12	29494	4/05/22 PAYROLL FUND NOW	315.64
13	29495	4/05/22 PAYROLL FUND NOW	29,187.03
14	29496	4/05/22 SEAN Q RAMKE	159.61
15	29497	4/05/22 LA DEPT OF PUBLIC SAFET	383.00
16	29498	4/06/22 PUBLIC IMPROVEMENT FUND	29.46
17	29499	4/07/22 PUBLIC IMPROVEMENT FUND	17.88
18	29500	4/07/22 PAYROLL FUND	137,006.38
19	29501	4/07/22 MUN EMPLOYEES RETIREMEN	8,412.47
20	29502	4/07/22 MUN EMPLOYEES RETIREMEN	5,382.69
21	29503	4/07/22 ACCOUNTS PAYABLE	23,967.18
22	29504	4/08/22 ACCOUNTS PAYABLE	49,400.00
23	29505	4/08/22 WILLIAM SPEARMAN	53.00
24	29506	4/11/22 PREMIUM SERVICES	1,139.09
25	29507	4/11/22 PUBLIC IMPROVEMENT FUND	10.09
26	29508	4/15/22 LAURA FREDERICK	391.66
27	29509	4/12/22 JACOB DUPONT	109.23
28	29510	4/12/22 PUBLIC IMPROVEMENT FUND	16.66
29	29511	4/13/22 PUBLIC IMPROVEMENT FUND	6.58
30	29512	4/13/22 PAYROLL FUND	1,643.46
31	29513	4/13/22 PAYROLL FUND	57.22
32	29514	4/13/22 PAYROLL FUND	45,717.62
33	29515	4/13/22 FIREFIGHTERS' RETIREMEN	51,306.80
34	29516	4/13/22 JACQUELINE HEBERT	13.70
35	29517	4/15/22 RANDALL ABSHIRE	950.00
36	29518	4/14/22 PUBLIC IMPROVEMENT FUND	7.23
37	29519	4/14/22 ACCOUNTS PAYABLE	17,236.82
38	29520	4/18/22 PUBLIC IMPROVEMENT FUND	21.87
39	29521	4/18/22 CIGNA	75.70
40	29522	4/19/22 JACOB DUPONT	100.36
41	29523	4/19/22 ACCOUNTS PAYABLE	107,438.91
42	29524	4/20/22 PUBLIC IMPROVEMENT FUND	12.73
43	29525	4/21/22 PAYROLL FUND	160,315.17
44	29526	4/21/22 PUBLIC IMPROVEMENT FUND	8.36
45	29527	4/21/22 ACCOUNTS PAYABLE	76,694.23
46	29528	4/25/22 JACOB DUPONT	125.54
47	29529	4/25/22 ROSLYN WHITE	553.21
48	29530	4/25/22 PUBLIC IMPROVEMENT FUND	24.95
49	29531	4/26/22 PUBLIC IMPROVEMENT FUND	14.21
50	29532	4/29/22 LAURA FREDERICK	391.66
51	29533	4/27/22 PUBLIC IMPROVEMENT FUND	7.96
52	29534	4/27/22 DAMIAN TRAHAN	5,300.00
53	29535	4/27/22 VIBRANDT MEDIA, LLC	150.00
54	29536	4/28/22 PAYROLL FUND	1,641.19
55	29537	4/28/22 PAYROLL FUND	52.02
56	29538	4/28/22 PAYROLL FUND	44,987.48
57			



CHECK NO.	DATE	C/L DESCRIPTION	CHECK AMOUNT
29539	4/28/22	ACCOUNTS PAYABLE	25,164.45
29540	4/29/22	PUBLIC IMPROVEMENT FUND	11.67
29541	4/29/22	VERIZON WIRELESS (POLIC	2,333.47

ACCT 001020 TOTALS 818,476.64  
FUND 00 TOTALS 818,476.64



POLICE DEPT MISC. ACCT. FUND  
DRUG FORFEITURE ACCOUNT

CHECK REGISTER 5/03/22

CHECK

CHECK  
AMOUNT

NO. DATE G/L DESCRIPTION

173 4/13/22 CASH 500.00

ACCT 001021 TOTALS 500.00

BOND FEE

CHECK

CHECK

NO.

DATE

G/L DESCRIPTION

AMOUNT

342

4/08/22

L A C P

26.00

ACCT

001026 TOTALS

26.00

FUND

04 TOTALS

526.00



MAINTENANCE & OPERATION -  
MAINT & OPER FIRE DEPT NOW

CHECK REGISTER 5/03/22

CHECK NO.	DATE	G/L DESCRIPTION	CHECK AMOUNT
14284	4/20/22	2016 REVENUE BONDS DEBT	7,289.50

ACCT 001020 TOTALS 7,289.50

FUND 05 TOTALS 7,289.50

CHECK NO.	DATE	G/L DESCRIPTION	CHECK AMOUNT
1			
2			
13689	4/14/22	ACCOUNTS PAYABLE	587.98
13690	4/19/22	ACCOUNTS PAYABLE	1,048.80
4			
5			
6			
7			
8			
9			
10			
11			
12			
13			
14			
15			
16			
17			
18			
19			
20			
21			
22			
23			
24			
25			
26			
27			
28			
29			
30			
31			
32			
33			
34			
35			
36			
37			
38			
39			
40			
41			
42			
43			
44			
45			
46			
47			
48			
49			
50			
51			
52			
53			
54			
55			
56			
57			

ACCT 001031 TOTALS 1,636.78



CHECK NO.	DATE	G/L DESCRIPTION	CHECK AMOUNT
1317	4/05/22	SPOTLESS CLEANING SYSTE	75.00
1318	4/07/22	ACCOUNTS PAYABLE	340.82
1319	4/14/22	ACCOUNTS PAYABLE	246.05
1320	4/19/22	ACCOUNTS PAYABLE	160.67
		ACCT 001032 TOTALS	822.54

CHECK NO.	DATE	G/L DESCRIPTION	CHECK AMOUNT
1163	4/07/22	ACCOUNTS PAYABLE	1,195.97
1164	4/14/22	ACCOUNTS PAYABLE	340.93
1165	4/19/22	ACCOUNTS PAYABLE	9.13
1166	4/26/22	CITY SALES TAX	200.00
1167	4/28/22	ACCOUNTS PAYABLE	1,136.10
		ACCT 001037 TOTALS	2,882.13
		FUND 06 TOTALS	5,341.45



CHECK NO.	DATE	G/L DESCRIPTION	CHECK AMOUNT
-----------	------	-----------------	--------------

15257	4/07/22	ACCOUNTS PAYABLE	549.43
15258	4/13/22	PAYROLL FUND	828.08
15259	4/14/22	ACCOUNTS PAYABLE	1,480.95
15260	4/18/22	SPRACO INC	550.00
15261	4/19/22	ACCOUNTS PAYABLE	154.80
15262	4/19/22	REHAB OF RW & PARTIAL T	123,082.20
15263	4/20/22	LAMA	225.00
15264	4/21/22	RAMON G LOA	350.00
15265	4/28/22	PAYROLL FUND	828.08
15266	4/28/22	ACCOUNTS PAYABLE	423.66

ACCT	001024	TOTALS	128,472.20
------	--------	--------	------------

FUND	07	TOTALS	128,472.20
------	----	--------	------------

PARK & RECREATION FUND  
PARK & RECREATION FUND ACCOUNT

CHECK REGISTER 5/03/22

CHECK NO.	DATE	G/L DESCRIPTION	CHECK AMOUNT
2187	4/01/22	QUALITY SPORTS AUTHORIT	8,334.00
2188	4/19/22	ACCOUNTS PAYABLE	775.00
		ACCT 001020 TOTALS	9,109.00
		FUND 10 TOTALS	9,109.00



CHECK NO.	DATE	G/L DESCRIPTION	CHECK AMOUNT
16974	4/07/22	ACCOUNTS PAYABLE	992.96
16975	4/08/22	BRANDON W BRIGGS	400.00
16976	4/14/22	ACCOUNTS PAYABLE	22,309.88
16977	4/19/22	IBERIA RENTAL SERVICE I	408.14
16978	4/19/22	ACCOUNTS PAYABLE	13,060.67
16979	4/20/22	2014 SALES TAX REVENUE	16,835.00
16980	4/20/22	2021 REVENUE BONDS DEBT	30,209.00
16981	4/21/22	BRANDON W BRIGGS	380.00
16982	4/21/22	RAMON G LOA	1,610.00
16983	4/26/22	PATRIOT CONSTRUCTION AN	18,264.18
16984	4/27/22	BRANDON W BRIGGS	1,000.00
16985	4/28/22	ACCOUNTS PAYABLE	40,061.18
16986	4/28/22	DAMIAN TRAHAN	2,500.00

ACCT 001021 TOTALS 148,031.01

FUND 11 TOTALS 148,031.01

CHECK NO.	DATE	G/L DESCRIPTION	CHECK AMOUNT
1191	4/07/22	GENERAL FUND	28,000.00
1192	4/13/22	GENERAL FUND	5,000.00
1193	4/13/22	UTILITY SYSTEM FUND	10,000.00
1194	4/21/22	GENERAL FUND	28,000.00
1195	4/27/22	GENERAL FUND	18,013.95
1196	4/27/22	UTILITY SYSTEM FUND	30,505.36
1197	4/28/22	GENERAL FUND	5,000.00
1198	4/28/22	UTILITY SYSTEM FUND	10,000.00

ACCT 001021 TOTALS 134,519.31

FUND 12 TOTALS 134,519.31



CHECK NO. DATE G/L DESCRIPTION CHECK AMOUNT

576 4/07/22 GENERAL FUND 30,000.00  
577 4/21/22 GENERAL FUND 30,000.00

ACCT 001020 TOTALS 60,000.00

FUND 13 TOTALS 60,000.00

REDEDICATED SALES TAX FUND  
REDEDICATED SALES TAX FUND

CHECK REGISTER 5/03/22

CHECK NO.	DATE	C/L DESCRIPTION	CHECK AMOUNT
1437	4/08/22	GENERAL FUND	49,400.00
1438	4/08/22	UTILITY SYSTEM FUND	15,600.00
1439	4/13/22	GENERAL FUND	21,000.00
1440	4/13/22	GENERAL FUND	17,000.00
1441	4/13/22	GENERAL FUND	6,285.00
1442	4/13/22	UTILITY SYSTEM FUND	7,375.00
		ACCT 001020 TOTALS	116,660.00
		FUND 14 TOTALS	116,660.00



CHECK NO.	DATE	G/L DESCRIPTION	CHECK AMOUNT
22285	4/07/22	OPTUMRX FOR RX CLAIMS	34,007.04
22286	4/07/22	OPTUMRX FOR RX FEES	70.60
22287	4/07/22	LA IMAGING SERVICES LLC	87.69
22288	4/07/22	ANN LAVERGNE LCSW LLC	89.59
22289	4/07/22	RYAN WINTERS	89.59
22290	4/07/22	LOUISIANA HEALTHCARE	12.84
22291	4/07/22	MYRIAM D HUTCHINSON	71.49
22292	4/07/22	LAFAYETTE HEALTH VENTURES	254.03
22293	4/14/22	GASTROENTEROLOGY CLINIC	504.27
22294	4/14/22	PAUL J TOMINO	154.88
22295	4/14/22	AMERIGROUP LOUISIANA	336.97
22296	4/14/22	MYRIAM D HUTCHINSON	58.78
22297	4/14/22	ABBEVILLE GENERAL HOSPITA	389.50
22298	4/14/22	LAFAYETTE HEALTH VENTURES	254.03
22299	4/21/22	OPTUMRX FOR RX CLAIMS	32,762.58
22300	4/21/22	OPTUMRX FOR RX FEES	67.80
22301	4/21/22	KATHLEEN S FAULK	549.00
22302	4/21/22	CHARLENE A DOMINGUE	44.14
22303	4/21/22	ANN LAVERGNE LCSW LLC	89.59
22304	4/21/22	OCHSNER CLINIC LLC NO	289.10
22305	4/21/22	OCHSNER CLINIC LLC NO	206.22
22306	4/21/22	NSI INC	70.00
22307	4/21/22	OCHSNER LAFAYETTE GENERAL	246.00
22308	4/21/22	UMR CRS FEES	588.71
22309	4/28/22	EXPRESS MED	111.81
22310	4/28/22	ACADIANA MEDICAL PSYCHOLD	179.18
22311	4/28/22	OPTION CARE HEALTH	274.80
22312	4/29/22	CENTENE MANAGEMENT CORP	6.28
22313	4/29/22	ACADIANA MEDICAL PSYCHOLD	89.59
40722	4/07/22	EFT FOR CLAIMS PAID	18,656.57
41422	4/14/22	EFT FOR CLAIMS PD	20,510.26
42122	4/21/22	EFT FOR CLAIMS PD	12,045.77
42822	4/28/22	EFT FOR CLAIMS PD	12,508.99
42922	4/29/22	EFT FOR CLAIMS PD	1,346.56

ACCT 001021 TOTALS 137,024.25



EMPLOYEE HEALTH INSURANCE FD  
 EMPLOYEE HEALTH INS. FUND NOW

CHECK REGISTER 5/03/22

CHECK NO.	DATE	Q/L DESCRIPTION	CHECK AMOUNT
1			
2	16209	4/01/22 UMR (HEALTH)	9,367.94
3	16210	4/01/22 UMR (STOP LOSS)	38,555.17
4	16211	4/01/22 THE HARTFORD	2,495.01
5	16212	4/08/22 EMPLOYEE HEALTH INSURAN	53,339.44
6	16213	4/08/22 ABBEVILLE GENERAL HOSPI	600.00
7	16214	4/13/22 UNITED HEALTHCARE INS.	4,460.72
8	16215	4/18/22 EMPLOYEE HEALTH INSURAN	22,208.69
9	16216	4/25/22 EMPLOYEE HEALTH INSURAN	46,958.91
10	16217	4/29/22 EMPLOYEE HEALTH INSURAN	13,074.78
11	16218	4/29/22 EMPLOYEE HEALTH INSURAN	1,442.43
12			
13			
14		ACCT 001025 TOTALS	192,503.09
15			
16		FUND 25 TOTALS	329,527.34
17			
18			
19			
20			
21			
22			
23			
24			
25			
26			
27			
28			
29			
30			
31			
32			
33			
34			
35			
36			
37			
38			
39			
40			
41			
42			
43			
44			
45			
46			
47			
48			
49			
50			
51			
52			
53			
54			
55			
56			
57			



CHECK NO.	DATE	G/L DESCRIPTION	CHECK AMOUNT
24005	4/07/22	PAYROLL FUND NOW	51,374.60
24006	4/07/22	VERMILION SCHOOL EMPLOY	1,600.53
24007	4/07/22	KEITH A RODRIQUEZ	57.70
24008	4/07/22	ABBEVILLE FIREFIGHTERS	300.00
24009	4/07/22	F O P ABBEVILLE LODGE 4	373.42
24010	4/07/22	DEPT OF CHILDREN AND FA	96.92
24011	4/07/22	DEPT OF CHILDREN AND FA	224.36
24012	4/07/22	DEPT OF CHILDREN AND FA	70.85
24013	4/07/22	TEXAS CHILD SUPPORT SDU	98.41
24014	4/13/22	PAYROLL FUND NOW	39,526.76
24015	4/13/22	VERMILION SCHOOL EMPLOY	1,760.00
24016	4/13/22	CITY COURT OF ABBEVILLE	107.15
24017	4/13/22	VALIC	950.00
24018	4/13/22	DEPT OF CHILDREN AND FA	169.60
24019	4/13/22	TEXAS CHILD SUPPORT SDU	173.54
24020	4/13/22	DEPT OF CHILDREN AND FA	149.74
24021	4/13/22	DEPT OF CHILDREN AND FA	215.06
24022	4/13/22	DEPT OF CHILDREN AND FA	24.22
24023	4/21/22	PAYROLL FUND NOW	59,536.44
24024	4/21/22	KEITH A RODRIQUEZ	57.70
24025	4/21/22	DEPT OF CHILDREN AND FA	96.92
24026	4/21/22	DEPT OF CHILDREN AND FA	290.76
24027	4/21/22	TEXAS CHILD SUPPORT SDU	67.23
24028	4/21/22	DEPT OF CHILDREN AND FA	113.88
24029	4/21/22	DEPT OF CHILDREN AND FA	198.20
24030	4/21/22	VERMILION SCHOOL EMPLOY	1,450.17
24031	4/21/22	ABBEVILLE FIREFIGHTERS	300.00
24032	4/21/22	F O P ABBEVILLE LODGE 4	373.42
24033	4/28/22	PAYROLL FUND NOW	38,289.05
24034	4/28/22	VERMILION SCHOOL EMPLOY	1,760.00
24035	4/28/22	CITY COURT OF ABBEVILLE	134.59
24036	4/28/22	VALIC	950.00
24037	4/28/22	UNITED WAY OF ACADIANA	85.50
24038	4/28/22	TEXAS CHILD SUPPORT SDU	173.54
24039	4/28/22	DEPT OF CHILDREN AND FA	24.22
24040	4/28/22	DEPT OF CHILDREN AND FA	169.60
24041	4/28/22	DEPT OF CHILDREN AND FA	215.06
24042	4/28/22	DEPT OF CHILDREN AND FA	149.74
4000000	4/06/22	PAYROLL FUND	85,054.65
4000000	4/13/22	PAYROLL FUND	79,961.70
4000000	4/20/22	PAYROLL FUND	101,742.99
4000000	4/27/22	PAYROLL FUND	77,744.82

ACCT 001020 TOTALS 546,233.04



CHECK NO.	DATE	G/L DESCRIPTION	CHECK AMOUNT	
1				
2	405	4/05/22	ACH FOR POL RET MAR	38,620.15
3	17472	4/07/22	MUN EMPLOYEES RETIREMEN	9,556.71
4	17473	4/08/22	ACCOUNTS PAYABLE	16,832.76
5	17474	4/13/22	FIREFIGHTERS' RETIREMEN	15,202.04
6	17475	4/19/22	WASHINGTON NATIONAL INS	1,481.76
7	17476	4/28/22	AMERITAS	6,815.32
8	17477	4/28/22	A F L A C INC	3,051.71
9	17478	4/28/22	TRANS AMERICA LIFE INS	635.77
10	17479	4/28/22	FAMILY LIFE INS CO	22.00
11	40122	4/01/22	BANK W/D FED W/H PR 4/1/2	21,068.53
12	40522	4/05/22	ACH FOR JUDGE'S RET MAR	398.70
13	40822	4/08/22	BANK W/D FED W/H PR 4/8/2	27,473.68
14	41422	4/14/22	BANK W/D FED W/H PR 4/14/	27,683.94
15	41422	4/14/22	BANK W/D STATE W/H PR 4/1	10,806.00
16	42222	4/22/22	BANK W/D FED W/H PR 4/22/	33,655.97
17	42922	4/29/22	BANK W/D FED W/H PR 4/29/	26,535.93
18				
19				
20		ACCT 001025 TOTALS	239,840.97	
21				
22		FUND 35 TOTALS	786,074.01	
23				
24				
25				
26				
27				
28				
29				
30				
31				
32				
33				
34				
35				
36				
37				
38				
39				
40				
41				
42				
43				
44				
45				
46				
47				
48				
49				
50				
51				
52				
53				
54				
55				
56				
57				



UTILITY SYSTEM FUND  
UTILITY SYSTEM FUND

CHECK REGISTER 5/03/22

CHECK NO	DATE	G/L DESCRIPTION	CHECK AMOUNT
1			
2	14079	4/01/22 TOSHIKA D WILSON	300.00
3	14080	4/01/22 ST MARY COMMUNITY ACTIO	227.63
4	14081	4/05/22 SPOTLESS CLEANING SYSTE	400.00
5	14082	4/07/22 PAYROLL FUND	2,272.06
6	14083	4/07/22 MUN EMPLOYEES RETIREMEN	18,014.05
7	14084	4/07/22 ACCOUNTS PAYABLE	15,577.94
8	14085	4/07/22 GENERAL FUND	30,000.00
9	14086	4/08/22 COMMITTEE OF CERTIFICAT	30.00
10	14087	4/08/22 JOHN JOSEPH	129.00
11	14088	4/08/22 ACCOUNTS PAYABLE	15,600.00
12	14089	4/08/22 BANK OF ABBEVILLE & TRU	51.39
13	14090	4/08/22 JENNY R HEBERT	307.07
14	14091	4/08/22 KAYLA R BRASSEAU	44.56
15	14092	4/08/22 CASEY ADAMS LOPEZ	80.00
16	14093	4/11/22 BANK OF ABBEVILLE & TRU	300.00
17	14094	4/11/22 CITY OF ABBEVILLE	60.31
18	14095	4/12/22 BANK OF ABBEVILLE & TRU	92.53
19	14096	4/13/22 UTILITY METER DEPOSIT F	120.00
20	14098	4/13/22 PAYROLL FUND	2,446.97
21	14099	4/13/22 PAYROLL FUND	72,354.92
22	14100	4/13/22 SAMUEL B WYATT	60.00
23	14101	4/13/22 GENERAL FUND	50,000.00
24	14102	4/13/22 TEHANNIE GALLEY AND	88.00
25	14103	4/14/22 ACCOUNTS PAYABLE	11,508.75
26	14104	4/14/22 GENERAL FUND	10,000.00
27	14105	4/18/22 ENTERGY	40.00
28	14106	4/19/22 ACCOUNTS PAYABLE	67,251.18
29	14107	4/19/22 GENERAL FUND	110,000.00
30	14108	4/19/22 MUN EMPLOYEES RETIREMEN	1,014.70
31	14109	4/20/22 FERNAND HEBERT, JR	102.59
32	14110	4/20/22 CITY OF ABBEVILLE	14.87
33	14111	4/21/22 PAYROLL FUND	3,959.54
34	14112	4/21/22 ACCOUNTS PAYABLE	24,022.50
35	14113	4/21/22 GENERAL FUND	160,000.00
36	14114	4/25/22 BANK OF ABBEVILLE & TRU	274.69
37	14115	4/25/22 BRANDON W BRIGGS	650.00
38	14116	4/26/22 CITY OF ABBEVILLE	16.99
39	14117	4/27/22 GENERAL FUND	95.00
40	14118	4/27/22 GUY POCHE	10.00
41	14119	4/27/22 CHRIS GAUTREAU	10.00
42	14120	4/28/22 PAYROLL FUND	2,532.05
43	14121	4/28/22 PAYROLL FUND	69,580.32
44	14122	4/28/22 ACCOUNTS PAYABLE	101,572.94
45	14123	4/28/22 GENERAL FUND	50,000.00
46			
47			
48		ACCT 001020 TOTALS	821,211.55
49			
50			
51			
52			
53			
54			
55			
56			
57			



UTILITY SYSTEM FUND  
 UTILITY SYSTEM FUND NOW

CHECK REGISTER 5/03/22

CHECK NO.	DATE	G/L DESCRIPTION	CHECK AMOUNT
422	4/19/22	EXELON GENERATION CO.	351,304.84
17651	4/01/22	UTILITY METER DEPOSIT F	300.00
17652	4/05/22	UTILITY METER DEPOSIT F	300.00
17653	4/05/22	GENERAL FUND	25,000.00
17654	4/06/22	UTILITY METER DEPOSIT F	600.00
17655	4/07/22	UTILITY METER DEPOSIT F	900.00
17656	4/07/22	UTILITY SYSTEM FUND	60,000.00
17657	4/08/22	UTILITY METER DEPOSIT F	300.00
17658	4/11/22	UTILITY METER DEPOSIT F	4,350.00
17659	4/12/22	UTILITY METER DEPOSIT F	600.00
17660	4/13/22	UTILITY SYSTEM FUND	110,000.00
17661	4/14/22	UTILITY METER DEPOSIT F	305.00
17662	4/14/22	UTILITY SYSTEM FUND	20,000.00
17663	4/18/22	UTILITY METER DEPOSIT F	600.00
17664	4/19/22	UTILITY SYSTEM FUND	175,000.00
17665	4/21/22	UTILITY SYSTEM FUND	190,000.00
17666	4/25/22	UTILITY METER DEPOSIT F	300.00
17667	4/26/22	UTILITY METER DEPOSIT F	300.00
17668	4/28/22	UTILITY SYSTEM FUND	180,000.00
17669	4/29/22	UTILITY METER DEPOSIT F	300.00
40822	4/08/22	MARCH 2022 SALES TAX	7,336.00
41122	4/11/22	ACH RETURN NSF C CANTRELL	73.63
41422	4/14/22	MISO INV 8542248410	3,550.09
41422	4/14/22	MISO INV 8542248401	63,859.85
41422	4/14/22	MISO INV 8542248402	4,441.17
ACCT 001083 TOTALS			1,199,720.58



UTILITY SYSTEM FUND  
UTILITY METER DEPOSIT FUND NOW

CHECK REGISTER 5/03/22

CHECK NO.	DATE	C/L DESCRIPTION	CHECK AMOUNT
13197	4/21/22	UTILITY METER DEPOSIT F	20,000.00
		ACCT 0010B4 TOTALS	20,000.00

1  
2  
3  
4  
5  
6  
7  
8  
9  
10  
11  
12  
13  
14  
15  
16  
17  
18  
19  
20  
21  
22  
23  
24  
25  
26  
27  
28  
29  
30  
31  
32  
33  
34  
35  
36  
37  
38  
39  
40  
41  
42  
43  
44  
45  
46  
47  
48  
49  
50  
51  
52  
53  
54  
55  
56  
57

UTILITY SYSTEM FUND  
 UTILITY METER DEPOSIT FUND

CHECK REGISTER 5/03/22

CHECK NO.	DATE	G/L DESCRIPTION	CHECK AMOUNT
22182	4/01/22	UTILITY SYSTEM FUND	5,038.38
22183	4/01/22	BRITTANI N DUHON	184.37
22184	4/01/22	TRINITY PATTERSON & KIR	253.86
22185	4/01/22	AARON BRIGGS	121.28
22186	4/01/22	ARIELLE S DAVIDSON	157.29
22187	4/01/22	ALAINA MARKS	205.94
22188	4/01/22	ANDRE'NEY R BROUSSARD	142.14
22189	4/01/22	ANDREANNA R BROUSSARD	225.56
22190	4/01/22	CASEY & COREY BURAS	265.00
22191	4/01/22	GLENN L GOTREAU	206.22
22192	4/01/22	CHRISTIAN A BROUSSARD	149.89
22193	4/01/22	EVANS R HARDY	287.39
22194	4/01/22	CLAUDETTE ANN CHIASSON	284.33
22195	4/01/22	JACK P ROMERO	293.61
22196	4/01/22	JUSTIN T MOUTON	271.20
22197	4/01/22	KENNEDY GORDON & KVAU W	284.72
22198	4/01/22	DEGRAAUW PROPERTY LLC	211.15
22199	4/01/22	JOHNNY DAVIS JR	74.44
22200	4/01/22	WAVERLY LEVERE	164.28
22201	4/05/22	UTILITY SYSTEM FUND	100.00
22202	4/07/22	JEREMY TOUCHET	197.88
22203	4/08/22	UTILITY SYSTEM FUND	100.00
22204	4/08/22	CASEY ADAMS LOPEZ	75.15
22205	4/12/22	MARILYN STEWART	200.00
22206	4/21/22	UTILITY SYSTEM FUND	3,780.94
22207	4/21/22	HARLIE HEBERT & ASHLEY	52.97
22208	4/21/22	CHOCOLATE CITY	219.61
22209	4/21/22	CLARA NICKERSON COLEMAN	108.66
22210	4/21/22	JADALE D WILLIAMS	96.67
22211	4/21/22	BRETT M HEBERT	256.62
22212	4/21/22	DIANE LUQUETTE	71.62
22213	4/26/22	JOSEPH C. BRENNAN	200.00
		ACCT 001085 TOTALS	14,311.17
		FUND 40 TOTALS	2,055,243.30



FEMA REIMBURSEMENT - HURRICANE  
FEMA & INS. REIM FUND NOW

CHECK REGISTER 5/03/22

CHECK NO.	DATE	Q/L DESCRIPTION	CHECK AMOUNT
244	4/07/22	ACCOUNTS PAYABLE	23,067.56
		ACCT 001020 TOTALS	23,067.56
		FUND 47 TOTALS	23,067.56

1  
2  
3  
4  
5  
6  
7  
8  
9  
10  
11  
12  
13  
14  
15  
16  
17  
18  
19  
20  
21  
22  
23  
24  
25  
26  
27  
28  
29  
30  
31  
32  
33  
34  
35  
36  
37  
38  
39  
40  
41  
42  
43  
44  
45  
46  
47  
48  
49  
50  
51  
52  
53  
54  
55  
56  
57

CHECK NO. DATE G/L DESCRIPTION CHECK AMOUNT

1016 4/21/22 FIRST HORIZON 191,009.25

ACCT 001021 TOTALS 191,009.25

FUND 51 TOTALS 191,009.25



PUBLIC IMPROVEMENT SEWERAGE FD  
PUBLIC IMPROVEMENT SEW. FD NOW

CHECK REGISTER 5/03/22

CHECK NO.	DATE	G/L DESCRIPTION	CHECK AMOUNT
14413	4/13/22	JACQUELINE HEBERT	3.43
14414	4/28/22	ACCDUNTS PAYABLE	5,750.00
		ACCT 001020 TOTALS	5,753.43
		FUND 55 TOTALS	5,753.43

1  
2  
3  
4  
5  
6  
7  
8  
9  
10  
11  
12  
13  
14  
15  
16  
17  
18  
19  
20  
21  
22  
23  
24  
25  
26  
27  
28  
29  
30  
31  
32  
33  
34  
35  
36  
37  
38  
39  
40  
41  
42  
43  
44  
45  
46  
47  
48  
49  
50  
51  
52  
53  
54  
55  
56  
57

AMERICAN RESCUE PLAN FUND  
AMERICAN RESCUE PLAN FUND

CHECK REGISTER 5/03/22

CHECK NO.	DATE	Q/L DESCRIPTION	CHECK AMOUNT
1012	4/20/22	SOUTHERN CONSTRUCTORS,	150,000.00
1013	4/21/22	ACCOUNTS PAYABLE	29,821.95
		ACCT 001021 TOTALS	179,821.95
		FUND 60 TOTALS	179,821.95

1  
2  
3  
4  
5  
6  
7  
8  
9  
10  
11  
12  
13  
14  
15  
16  
17  
18  
19  
20  
21  
22  
23  
24  
25  
26  
27  
28  
29  
30  
31  
32  
33  
34  
35  
36  
37  
38  
39  
40  
41  
42  
43  
44  
45  
46  
47  
48  
49  
50  
51  
52  
53  
54  
55  
56  
57



COMEAUX PARK RENOVATION FUND  
COMEAUX PARK RENOVATION FUND

CHECK REGISTER 5/03/22

CHECK NO.	DATE	G/L DESCRIPTION	CHECK AMOUNT
1021	4/06/22	GEDSURFACES, INC	235,125.00
1022	4/07/22	ACCOUNTS PAYABLE	120,067.90
		ACCT 001020 TOTALS	355,192.90
		FUND 62 TOTALS	355,192.90

1  
2  
3  
4  
5  
6  
7  
8  
9  
10  
11  
12  
13  
14  
15  
16  
17  
18  
19  
20  
21  
22  
23  
24  
25  
26  
27  
28  
29  
30  
31  
32  
33  
34  
35  
36  
37  
38  
39  
40  
41  
42  
43  
44  
45  
46  
47  
48  
49  
50  
51  
52  
53  
54  
55  
56  
57

AIRPORT IMPROVEMENT FUND  
 REHAB OF RW & TW

CHECK REGISTER 5/03/22

CHECK NO.	DATE	G/L DESCRIPTION	CHECK AMOUNT
1015	4/19/22	SELLERS & ASSDC INC	41,992.36
1016	4/19/22	ELLIOTT CONSTRUCTION, L	81,089.31
1017	4/19/22	AIRWAY INDUSTRIAL PARK	.53
		ACCT 001033 TOTALS	123,082.20
		FUND 63 TOTALS	123,082.20



LCDBG IMPROVEMENT PROJECT FUND  
 LCDBG CLEARANCE PROGRAM

CHECK REGISTER 5/03/22

CHECK NO.	DATE	Q/L DESCRIPTION	CHECK AMOUNT
1022	4/06/22	UTILITY SYSTEM FUND NOW	176.75
1023	4/12/22	UTILITY SYSTEM FUND NOW	208.27
1024	4/13/22	GUARINO BLACKSMITH SHOP	485.90
1025	4/13/22	UTILITY SYSTEM FUND NOW	250.20
1026	4/19/22	GENERAL FUND	241.00
1027	4/19/22	CITY SALES TAX	41,130.00
		ACCT 001028 TOTALS	42,492.12
		FUND 65 TOTALS	42,492.12

The following was offered by \_\_\_\_\_, seconded by \_\_\_\_\_, and duly resolved:

**RESOLUTION NO. \_\_\_\_\_**  
**A RESOLUTION REQUESTING FINANCIAL ASSISTANCE**  
**FROM THE STATE OF LOUISIANA**  
**UNDER SEDAP - DELTA REGIONAL**  
**AUTHORITY PROGRAM**

**WHEREAS**, the State of Louisiana has announced that applications are being accepted for the States' Economic Development Assistance Program (SEDAP), funded by the Delta Regional Authority (DRA); and

**WHEREAS**, the States' Economic Development Assistance Program offers grants to eligible municipalities and parishes for a wide range of projects to build basic public infrastructure, build transportation infrastructure, promote business development with an emphasis on entrepreneurship, and promote workforce development; and

**WHEREAS**, it is deemed necessary and proper for the City of Abbeville to submit application(s) to the States' Economic Development Assistance Program; and

**WHEREAS**, the City of Abbeville hereby commits to a local match to fund all costs over the grant award.

**NOW, THEREFORE, BE IT RESOLVED** by the City of Abbeville that Sellers & Associates is hereby authorized to submit the necessary documents for the SEDAP - DRA on behalf of the City of Abbeville, and that the Mayor is hereby authorized to sign all documents related to the States' Economic Development Assistance Program.

**THEREUPON**, the above resolution was approved.

\*\*\*\*\*

**C E R T I F I C A T E**

I, Kathy Faulk, Clerk of the City of Abbeville , do hereby certify that the above is a true and exact copy of a resolution adopted by the Councilmen of the City of Abbeville on \_\_\_\_\_, 2022, at which time a quorum was present and voting.

\_\_\_\_\_  
KATHY FAULK, CLERK  
CITY OF ABBEVILLE LOUISIANA



Remit To:

Event Solutions  
 1701 West Willow Street  
 Scott, LA 70583  
 www.eventsolutionsweb.com

# Invoice

Continued	Invoice#
Thu 4/ 7/2022	157946-1

Customer #: 8548

City of Abbeville  
 P. O. Box 1170  
 Abbeville, LA 70511

Job Descr: Comeaux Park

Date Out Thu 3/10/2022

Terms	Aging Date
Net 30	Thu 4/ 7/2022

Fold Here

Fold Here

Ordered By: Tommy Picard

Salesman: Danielle Demette

**Used at Address**

Tommy Picard 337-319-9288  
 Comeaux Park  
 300 A A Comeaux Memorial Dr  
 ABBEVILLE, LA 70510

Qty	Items Rented	Each	Disc%	Rental Period	Price
4	Restroom Trailer Pump Service 1x week service	\$400.00		Thu 3/10/2022 to Thu 4/ 7/2022	\$1,600.00
1	Restroom Trailer 7 stall RT#31 1 month rental rate	\$3,000.00		Thu 3/10/2022 to Thu 4/ 7/2022	\$3,000.00
1	Portable Toilet Handicap Rental	\$15.00		Thu 3/10/2022 to Thu 4/ 7/2022	\$15.00
1	Handicap Toilet Waste Removal 1x week service	\$180.00		Thu 3/10/2022 to Thu 4/ 7/2022	\$180.00

**Total for Rental \$4,795.00**

Qty	Items Sold	Each	Disc%		Price
1	Delivery/ Pickup Fee ES	\$350.00			\$350.00

**Total for Sales \$350.00**

30+ Days aged

**Please pay from this invoice.**

Rental and Sales:					Tax Exempt:
\$5,145.00					\$0.00

Total Amount:	\$5,145.00	Total Paid	\$0.00	Total Due	\$5,145.00
---------------	------------	------------	--------	-----------	------------

337-261-2459

www.eventsolutionsweb.com

3372613391

Remit To:

Event Solutions  
 1701 West Willow Street  
 Scott, LA 70583  
 www.eventsolutionsweb.com

**Invoice**

Continued	Invoice#
Fri 5/ 6/2022	157946A-1

Customer #: 8548

Job Descr: Comeaux Park

**City of Abbeville**  
 P. O. Box 1170  
 Abbeville, LA 70511

Date Out Thu 4/ 7/2022

Terms	Aging Date
Net 30	Fri 5/ 6/2022

Fold Here

Fold Here

**Ordered By:** Tommy Picard

**Salesman:** Danielle Demette

**Used at Address**

Tommy Picard 337-319-9288  
 Comeaux Park  
 300 A A Comeaux Memorial Dr  
 ABBEVILLE, LA 70510

Qty	Items Rented	Each	Disc%	Rental Period	Price
4	Restroom Trailer Pump Service 1x week service	\$400.00		Thu 4/ 7/2022 to Thu 5/ 5/2022	\$1,600.00
1	Restroom Trailer 7 stall RT#31 1 month rental rate	\$3,000.00		Thu 4/ 7/2022 to Thu 5/ 5/2022	\$3,000.00
1	Portable Toilet Handicap Rental	\$15.00		Thu 4/ 7/2022 to Thu 5/ 5/2022	\$15.00
1	Handicap Toilet Waste Removal 1x week service	\$180.00		Thu 4/ 7/2022 to Thu 5/ 5/2022	\$180.00

**Total for Rental \$4,795.00**

Current On Account

**Please pay from this invoice.**

Rental and Sales:		Damage Waiver:	Subtotal:	Tax Exempt:
\$4,795.00		\$300.00	\$5,095.00	\$0.00

Total Amount:	\$5,095.00	Total Paid	\$0.00	Total Due	\$5,095.00
---------------	------------	------------	--------	-----------	------------

337-261-2459

www.eventsolutionsweb.com

3372613391



Remit To:

Event Solutions  
 1701 West Willow Street  
 Scott, LA 70583  
 www.eventsolutionsweb.com

# Invoice

Open	Invoice#
Thu 5/ 5/2022	157946B-1

Customer #: 8548

City of Abbeville  
 P. O. Box 1170  
 Abbeville, LA 70511

Job Descr: Comeaux Park

Date Out Thu 5/ 5/2022

Terms	Aging Date
Net 30	Thu 5/ 5/2022

Fold Here

Fold Here

**Ordered By:** Tommy Picard

**Salesman:** Danielle Demette

**Used at Address**

Tommy Picard 337-319-9288  
 Comeaux Park  
 300 A A Comeaux Memorial Dr  
 ABBEVILLE, LA 70510

Qty	Items Rented	Each	Disc%	Rental Period	Price
4	Restroom Trailer Pump Service 1x week service	\$400.00		Thu 5/ 5/2022 to Thu 6/ 2/2022	\$1,600.00
1	Restroom Trailer 7 stall RT#31 1 month rental rate	\$3,000.00		Thu 5/ 5/2022 to Thu 6/ 2/2022	\$3,000.00
1	Portable Toilet Handicap Rental	\$15.00		Thu 5/ 5/2022 to Thu 6/ 2/2022	\$15.00
1	Handicap Toilet Waste Removal 1x week service	\$180.00		Thu 5/ 5/2022 to Thu 6/ 2/2022	\$180.00

**Total for Rental \$4,795.00**

**Current On Account**

**Please pay from this invoice.**

Rental and Sales:		Damage Waiver:	Subtotal:	Tax Exempt:
\$4,795.00		\$300.00	\$5,095.00	\$0.00

<b>Total Amount:</b>	<b>\$5,095.00</b>	<b>Total Paid</b>	<b>\$0.00</b>	<b>Total Due</b>	<b>\$5,095.00</b>
----------------------	-------------------	-------------------	---------------	------------------	-------------------

337-261-2459

www.eventsolutionsweb.com

3372613391

The City of Abbeville, Parish of Vermilion, met in regular session on May 17, 2022. The following resolution was offered by \_\_\_\_\_ and seconded by \_\_\_\_\_.

**RESOLUTION NO. \_\_\_\_\_**

A resolution authorizing the Mayor to execute Agreements with the Louisiana Department of Transportation and Development (LA DOTD) and with the Federal Aviation Administration (FAA) and to award and sign related contracts for FY 2022 projects at the Chris Crusta Memorial Airport.

**WHEREAS**, Act 451 of the 1989 Regular Session of the Louisiana Legislature authorized the financing of certain airport improvements from funds appropriated from the Transportation Trust Fund and the FAA has issued a federal grant/funding allocation for this project; and

**WHEREAS**, the City of Abbeville has requested funding assistance from the FAA and LA DOTD for the Construct Hangar Development Area (Phase I Design) project for the Chris Crusta Memorial Airport; and

**WHEREAS**, the stated project has been approved by the Louisiana Legislature and the LA DOTD and the FAA is agreeable to the implementation of this project and desires to cooperate with the City of Abbeville according to the terms and conditions identified in said Agreements.

**NOW THEREFORE, BE IT RESOLVED** by the City of Abbeville that it does hereby authorize the Mayor to execute said Agreements and award and sign associated contracts, contingent upon DOTD and FAA grant award and approval, for said projects at the Chris Crusta Memorial Airport identified as FAA AIP No. 3-22-0001-023-2022 and State Project No. H.0XXXXXX (to be determined).

This resolution shall be in full force and effect from and after its adoption.

This aforesaid resolution, having been submitted to a vote, the vote thereon was as follows:

YEAS: \_\_\_\_\_

\_\_\_\_\_

NAYS: \_\_\_\_\_

\_\_\_\_\_

ABSENT: \_\_\_\_\_

**WHEREUPON**, the resolution was declared adopted on the \_\_\_ day of \_\_\_\_\_, 2022.

CITY OF ABBEVILLE

BY: \_\_\_\_\_  
*Signature*

Kathy Faulk  
\_\_\_\_\_  
*Typed or Printed Name*

TITLE: Secretary-Treasurer



# Memo

**To:** Mayor Mark Piazza  
**From:** Chris Gautreaux  
**cc:** Name  
**Date:** 5-15-2022  
**Re:** Fire Hydrants

---

This would be the remaining fire Hydrants that were ordered for us at the old price. 14 hydrants at a cost of 1988.13 for a total of 27833.82

Thanks

Chris Gautreaux



**QUOTATION**

Customer#: 37001500  
 CITY OF ABBEVILLE  
 PO BOX 1170  
 ABBEVILLE, LA 70511-1179

Page#: 2 of 2

Branch#: 2  
 COBURN SUPPLY COMPANY, INC.  
 530 N PIERCE ST  
 LAFAYETTE, LA 70501  
 337-232-2321  
 Fax 337-233-7830

Quote#	Start Date	Exp. Date	Job Name	Bid Type	Prepared By
1104639	05/03/22	05/08/22	FIRE HYDRANTS	UTILITY	ELLIOT ROMERO

Line#	Qty	Per	Product No. & Description	Unit Price	Ext. Price
1	14	EA	S-1 ==>ML 64500056 129S FIRE HYD 3-6 RED C502 51/4" 3 WAY 6" MJ L/ACC [TRAFFIC MODEL]	1988.13	27833.82
			QUOTATION TOTAL	*****	27833.82
				Initial	27833.82



**Company Name**

# Memo

**To:** Mayor Mark Piazza  
**From:** Chris Gautreaux  
**cc:** Name  
**Date:** 05-16-22  
**Re:** Backflow Preventer

---

Replace backflow preventer at sewer plant by Bhim Construction in the amount of \$25,000.00. This will include putting the 4-inch backflow preventer above ground to prevent the rusting of the new backflow preventer as the rain water stays above the backflow preventer that is now inside of the below ground concrete basin and move the backflow preventer back and out of the ground from its original location to prevent any vehicle from hitting it. If sand is needed and/or the removal of concrete is needed the city will provide.

Thanks

Chris Gautreaux



Building on a tradition of success

May 16, 2022

via e-mail: [lschexnaider@cityofabbeville.net](mailto:lschexnaider@cityofabbeville.net)

City of Abbeville  
c/o Lee Schexnaider  
101 N. State Street  
Abbeville, LA 70510

Attention: Lee Schexnaider

Reference: Wastewater Plant Lime Dust Collector

Lee,

MMR Group proposes to provide all labor, tools, and equipment to remove old lime dust collector and install new lime dust collector. Install new stainless steel disconnects for blower and shaker motors and terminate with new electrical conduit and fittings from end of ridged conduit on top of lime bin to all equipment.  
Function test and demonstrate operation for customer.

**Budgetary Estimate: . . . . . \$ 7,050.00**

We appreciate this opportunity to serve your company and look forward to working with you on this and future projects. Should additional information be required, please do not hesitate to notify me at (337) 201-0969.

Sincerely,

*Jon M DeRouen*

Jon DeRouen | Project Manager | MMR Group, Inc.  
1043 QCP Park Drive | Broussard, LA 70518  
(O) 337-367-5494 | (C) 337-201-0969 | (D) 337-735-8269  
| Website | Videos & Brochure



**MMR Offshore Services**  
A division of MMR Constructors, Inc.

1043 QCP Park Drive | Broussard, LA 70518  
(P) 337-367-5494 | (F) 337-367-6762 | [www.mmrgroup.com](http://www.mmrgroup.com)





# GRIFFIN FILTER TECHNOLOGIES INC.

106 METROPOLITAN PARK DRIVE ♦ LIVERPOOL, NY 13088, USA

Tel: (315) 451-5300 ♦ Fax: (315) 451-2338

*Better Environmental Solutions by Design™*

Proposal Number: 222055

Date: 04/25/2022

Customer Information	Representative Information
Lee Schexnaider City of Abbeville Phone: 337-319-4772 Email: <a href="mailto:lschexnaider@cityofabbeville.net">lschexnaider@cityofabbeville.net</a>	Michelle Andraous Griffin Filter Technologies Inc. 106 Metropolitan Park Drive Liverpool, NY 13088 Phone : (315) 451-5300 x 104 Email : <a href="mailto:handraous@griffinfilters.com">handraous@griffinfilters.com</a>

## DESCRIPTION OF APPLICATION:

Process Description	Cement silo fill
Dust Description	Cement
Inlet Dust Loading	
Air Flow in ACFM	
Air Flow Temperature in °F	
Hazardous? Please circle or check	No <input checked="" type="checkbox"/> Combustible <input type="checkbox"/> Explosive <input type="checkbox"/> Toxic <input type="checkbox"/>
<b>If hazardous, the user must supply the following information for NFPA/OSHA compliance:</b>	
Hazard category – please circle or check	Dust <input type="checkbox"/> Gas <input type="checkbox"/> Mist <input type="checkbox"/> Hybrid <input type="checkbox"/>
Toxicity – maximum emissions allowable in lbs/hour, day, year	NA
Minimum Combustion Temperature in °F	NA
Deflagration Index of a dust cloud (Kst) or gas (Kg) (list max. value) in ___ bar-m/s	NA
Maximum Pressure of an unvented deflagration (Pmax) (list max. value) in ___ bar	NA
Source of above data – please circle or check	Testing <input type="checkbox"/> Tables <input type="checkbox"/> Other <input type="checkbox"/>
Electrical Classification:	Class 1, Div 1: <input type="checkbox"/> Flammable gases or vapors exist under normal conditions. (NEMA 7)
	Class 1, Div 2: <input type="checkbox"/> Flammable gases or vapors may be present but do not exist under normal conditions. (NEMA 7)
	Class 2, Div 1: <input type="checkbox"/> Combustible dusts exist under normal conditions. (NEMA 9)
	Class 2, Div 2: <input type="checkbox"/> Combustible dusts may be present but do not exist under normal conditions. (NEMA 4 or 9)



Griffin Filters Design and Application Engineers recommend for your application:

**Model 36-LS Fan Assisted Shaker Silo Filter Vent Dust Collector**

Description	Price
<p><b>Baghouse Description:</b></p> <ul style="list-style-type: none"> <li>A- All welded construction using 12-gauge HRS</li> <li>B- Tubesheet constructed of 12-gauge HRS</li> <li>C- (36) - 4" x 79" woven polyester bags. Cloth area = 250 ft<sup>2</sup>.</li> <li>D- Bags have grommet top, snap spring bottom.</li> <li>E- Shaker Motor - Internal 1/6HP, 1800 RPM, 115/1/60, TEFC. <i>(Shaker Control Panel Mini C8 panel (optional) Listed under Options)</i></li> <li>F- (1) Access door for bag removal is provided on front of unit.</li> </ul>	Included
<p><b>Blower Assembly</b></p> <ul style="list-style-type: none"> <li>A- 5 HP, 3600 RPM 230-460/3/60, TEFC motor.</li> <li>B- Cast aluminum fan wheel, direct driven.</li> <li>C- Low side mounted on collector (approximately 4' above mounting flange).</li> <li>D- Performance = 1280 CFM @ 6" SP and 70° F.</li> </ul>	Included
<p><b>Surface Preparation and Paint:</b></p> <ul style="list-style-type: none"> <li>A- Internal welds are stitch welds. No grinding. Internal surfaces are finished as welded.</li> <li>B- Internal surfaces are unpainted.</li> <li>C- External welds are continuous, no grinding, with a generally neat and rounded profile, some stop/start areas.</li> <li>D- External surfaces receive power tool and solvent cleaning.</li> <li>E- External surfaces receive one coat of red-oxide primer and one finish coat "Griffin" tan paint. Blue and gray also available. Tan is the standard color. Other colors available upon request and may be subject to additional charges.</li> </ul>	Included
<b>TOTAL – Baghouse and Surface Prep/Paint:</b>	<b>\$7,650.00</b>
<b>Estimated freight to Abbeville (subject to change)</b>	<b>\$1,200.00</b>





<b>Options, Accessories, and Upgrades</b>	
<b>Mini C-8 Control Panel:</b> - Shaker Blower Controller - (PN: 825 mini C8) (Starter Motor by others if required)	\$995.00
<b>Dwyer Model 2010 Magnehelic Gauge</b> with mounting kit (PN 950-2010MGH Kit)	\$240.00
<b>Silo Pressure Relief Valve:</b> A- Opens in the range of 0.5 to 1 psi	\$295.00
<b>Companion Flange</b> A- 1.5" tall for mounting silo vent to silo	\$295.00
<b>Slanted Roof Adaptor</b> A- 6" short side and 16" long side (18-degree slope ) for mounting silo vent to silo	\$395.00
<b>Box Roof Adaptor</b> A- 6" tall box for mounting silo vent to silo	\$350.00
<b>RECOMMENDED SPARE PARTS:</b>	
<b>Bags:</b> A- Quantity 36 - PN. 550-479 DG (79" filters). For model 36LS	\$19.75 ea
<b>Repair Kits</b> A- Quantity 1 PN (825-RK1) (Shaker Mechanism) B- Quantity 1 PN (825-RK2) (Shaker Rack Hanger Parts) x 4. The unit requires 4 kits – one per corner of the rack.  <i>See Information Below</i>	\$175.00 \$22.00 ea

Drawings with part call-outs and parts list shown below.





**REPLACEMENT PARTS**

ITEM#	DESCRIPTION	PART #
<b>SHAKER DRIVE TRAIN KIT - RK1</b>		
This kit includes items 1 - 5		
1.	3/8" Radial Bearing	
2.	3/8" X 7" Mill Stud Fine	
3.	1/2" Brass Eccentric	
4.	5/16" x 5/8" Shoulder Bolt	
5.	1/2" Saw Mandrel	
<b>SHAKER MOTOR, V-BELT DRIVE PARTS</b>		
6.	Large Pulley - 6"PD x 1/2" Bore	400-AK64 1/2
7.	V-Belt	400-4L290
8.	Motor Pulley	400-AK17 1/2
9.	Motor (See Chart on Page 1)	
	1/6 HP, 1800, 115/1/60	300-1/6 1800 48T
	1/6 HP, 1200, 115/1/60	300-1/6 1200 48T
	1/4 HP, 1200, 230/460/3/60	300-1/4 1200 48T
<b>SHAKER RACK HANGER PARTS KIT - RK2</b>		
This kit includes items - 10 - 15		
10.	3/8" Yoke End	
11.	3/8" Clevis Pin	
12.	1/16" x 7/8" Cotter Pin	
13.	3/8" - 24 UNF x 3 1/4" Threaded Rod	
14.	3/8" Oilite Bearing	
15.	3/8" 24 Nut	
<b>BAGS</b>		
16.	J Hook	250-F14SH
17.	Bags (See chart on page 1)	
	4" x 38 1/2" Snap In Filter Bag	550-438-DG
	4" x 79" Snap In Filter Bag	550-479-DG
<b>DOOR GASKET</b>		
18.	1" x 1/4" Poron Urethane W/PSA	450-114POR

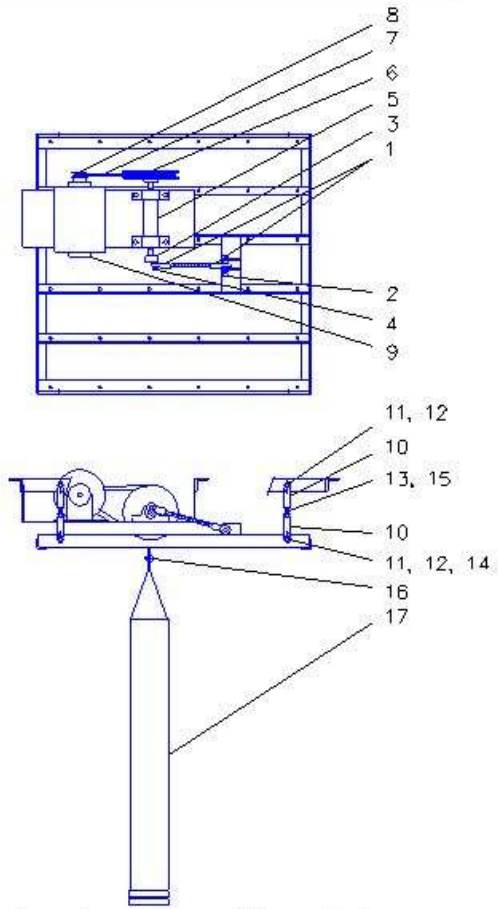

When ordering parts, please include model & serial number of unit to insure the proper part will be received.

*Griffin Bags and Griffin Parts...*  
 When you need replacement items remember...  
**KEEP YOUR COLLECTOR ALL GRIFFIN**





**Terms and Conditions of Sales Contract**

Please include acceptance and agreement to abide by the terms and conditions put forth in this proposal in you purchase order documents.

**PROPOSAL PRICES ARE F.O.B. ORIGIN****CUSTOMER IS RESPONSIBLE FOR ALL FREIGHT CHARGES**

- Freight charges include coverage for dust collector/baghouse and major systems components shipped directly to the fabricator or customer site for system integration (filters, cages, fans, rotary airlocks, etc.)
- Freight charges may be invoiced separately
- Pre-paid and added freight is subject to up to a 10% freight handling charge

**PRODUCTION SCHEDULE:**

A- APPROVAL DRAWINGS: 1-2 days to send detailed Approval Drawings (if required)

B- SHIPMENT: 4 to 8 Weeks after finalized Approval Drawings are returned to Griffin Filters

**Note:** Shipment subject to shop schedule upon return of approval drawings.

**PAYMENT TERMS:**

Manufacturing Stage	%	Terms
Purchased Order placed	50%	Due upon receipt of invoice
Balance Due	50%	Prior to Shipment

**Note:** Payment terms are subject to credit review. All amounts which are outstanding and unpaid for more than 30 days will be subject to a late charge at the rate of one and one-half percent (1.5%) per month.

**PROPOSAL EXPIRATION:**

This proposal will remain in effect for a period of thirty (30) days.

- Any contract resulting from this proposal is subject to Griffin Filters' written acceptance.
- Due to the volatility of steel pricing, this quotation and any subsequent order resulting from this quotation, is subject to price adjustments.

**TERMS AND CONDITIONS OF SALE:**

This proposal is submitted in accordance with Griffin Filters' Standard Terms and Conditions and are attached and made part of this proposal.

Thank you for the opportunity to offer this proposal.

Sincerely,

*Michelle Andraous*

Applications Engineer  
Griffin Filter Technologies Inc



## **COLLECTION EFFICIENCY**

Griffin Filters guarantees that the fabric filter dust collectors, as quoted in Griffin Filters' proposals, will collect, at a minimum, 99.9%+ down to 1 micron based on the weight of the suspended solids contained in the gas entering the dust collector. An outlet loading of .02 grains per actual cubic foot or less shall constitute fulfillment of the guarantee and current requirements. This guarantee is based on the parameters as outlined in the proposal. The guarantee is invalid if the equipment is not installed, properly pre-coated, operated, or maintained within the guidelines of Griffin's installation, operation, and maintenance manual.

Testing shall be done using EPA test method 5.

If test results indicate the dust collectors are out of compliance, Griffin personnel shall address the problem in the following manner:

- 1) If bag material or workmanship is found to be the cause of the non-compliance, Griffin will replace the bags in question at no charge or make compensation to the end user in the amount of our cost of the bags to be replaced on a one-for-one basis.
  
- 2) If the failure is a result of faulty installation, faulty operation, or incorrect maintenance, or the system failure is a result of continuous operation in an upset condition, or the operating conditions have been altered from those defined in the initial specification, then all guarantees and warranties are void.





# GRIFFIN FILTERS

106 METROPOLITAN PARK DRIVE ♦ LIVERPOOL, NY 13088, USA  
Tel: (315) 451-5300 ♦ Fax: (315) 451-2338

## STANDARD TERMS AND CONDITIONS OF SALE

- PURCHASE AND SALE.** Upon acceptance of the equipment and/or services proposal and quotation (the "Proposal and Quotation") of which these Standard Conditions of Sale are made a part by the Buyer (as identified on the Equipment and/or Services Quotation page), Griffin Filters LLC.. (the "Seller") shall sell and Buyer shall purchase all of the equipment (hereinafter collectively called the "Equipment") described in the Proposal and Quotation for the sale price specified therein in accordance with all of the terms and conditions hereinafter set forth, as well as with all of the other provisions of the Proposal and Quotation. Except where the context requires otherwise, the terms "herein," "hereof," "hereunder," and other words of similar import refer to the Proposal and Quotation as a whole, and not to any particular article, section, paragraph, clause, attachment or other subdivision thereof.
- SALE PRICE AND PAYMENT TERMS.** The sale price of the Equipment specified in the Proposal and Quotation does not include any applicable sales, use, excise or other similar taxes imposed by any federal, state, local or other taxing jurisdiction. If any such taxes are imposed with respect to the sale of the Equipment, Buyer shall pay the same. Seller may require that Buyer pay such taxes directly or, in the alternative, Seller may pay the taxes due on behalf of Buyer and obtain reimbursement from Buyer immediately upon Seller's demand. The terms of payment of the sale price of the Equipment are as set forth on the Equipment and/or Services Quotation page. In the event fabrication is delayed by Buyer for any reason, to include delays in returning required approval drawings, project delays not attributable to Seller's equipment, and system or equipment redesign, and cost increases due to such delay are incurred by Seller, Seller reserves the right to pass such cost increases to Buyer by amending the Purchase Order agreement or by other means acceptable to both parties. All payments, including any contract cost increases, must be made to Seller promptly when due at its Home Office address indicated in the Proposal, Quotation, or Invoice document(s).
- DELIVERY AND RISK OF LOSS.** Any delivery made within 30 days after the end of the respective delivery times specified on the Equipment and/or Services Quotation page is to be deemed to be timely. Subject to the Force Majeure provisions of paragraph 9 below, if Seller fails timely to deliver any of the Equipment, Buyer may cancel that portion of the Equipment which has been delayed, such right of cancellation being Buyer's sole remedy for Seller's failure or delay in making delivery. Risk of loss and damage to the Equipment will automatically be transferred and will pass from Seller to Buyer upon delivery or tender of the Equipment at the F.O.B. place of delivery specified on the Equipment and/or Services Quotation page. Except to the extent provided to the contrary in paragraph 9 below, no loss, destruction or other material damage to the Equipment will relieve the party bearing the risk of loss and damage from fully performing its obligations hereunder.
- INVOICES.** The Equipment may be delivered, at the discretion of the Seller, in several lots under separate invoices. In such event, Buyer shall promptly pay the proportionate amount of the total sale price of the Equipment represented by each lot indicated in the invoice furnished by Seller respecting such lot.
- SECURITY INTEREST.** As security for the full and prompt payment of the sale price of the Equipment, as well as of all other amounts now or hereafter owing by Buyer to Seller of whatever nature, Buyer grants to Seller a present and continuing first priority, purchase money security interest in the Equipment. If Buyer fails promptly to pay, when due, any amount payable hereunder, then Seller may, without any notice or demand of any kind and notwithstanding any other provisions or agreements to the contrary, declare all amounts then owing by Buyer to Seller to be due and payable, whereupon the same will immediately become due and payable; and Seller may exercise from time to time all rights and remedies available to it hereunder or available under applicable law or in equity. Buyer shall pay all costs and expenses incurred by Seller in collecting any amount owing by Buyer to Seller (including, but not limited to, reasonable attorney's fees, if collected by or through an attorney at law).
- WARRANTIES.**  
**(A) Limited Warranty of Equipment Manufactured by Seller.** Subject to the limitations hereinafter set forth, Seller warrants to Buyer that all items of the Equipment manufactured by Seller will be free from defects in material and workmanship under normal use and service for a period of 12 months after the date of delivery or tender of the Equipment to Buyer, or 12 months after the date that the Equipment is ready for commencement of initial operation by Buyer, whichever occurs first; provided, however, that (i) the Equipment must at all times have been operated in accordance with Seller's operating instructions and in accordance with the conditions for which the same are designed and (ii) no alterations or substitutions have been made in the Equipment. The seller assumes no responsibility or expense of erection. The correction of minor misfits and a reasonable amount of cutting, reaming or redrilling will be considered as legitimate expense of erection. Any error in shop fabrication which prevents the proper assembling and alignment of parts by the moderate use of reamers, drift pins or cutting shall be immediately reported to the Seller and approval obtained for the method of correction. Further, and without limiting the foregoing, the limited warranty herein given by Seller will be rendered void by the improper erection of the Equipment by parties other than Seller or by damage to the Equipment after transfer and passage of the risk of loss from Seller to Buyer (including, but not limited to, damage caused by abrasion, corrosion, excess temperature or improper use). Buyer shall make all claims of any nature whatsoever for breach of the foregoing limited warranty, regardless of whether a defect is patent or latent, by written notice to Seller within 10 days after Buyer discovers such defect, setting forth in detail the nature of defect. Buyer's right to make claims for breach of said limited warranty will terminate upon the expiration of such notice period, and all claims for defects will thereafter be barred. Upon Buyer's making a satisfactory written proof of claim with Seller, Seller may fully discharge its obligations under this limited warranty by making any necessary repairs or, at Seller's option, supplying replacement parts within a reasonable period of time thereafter, all at Seller's expense. No payment or allowance will be made for labor costs, parts or other charges of Buyer or of third parties for making repairs or replacements, nor will Seller accept Equipment returned for credit, unless written authorization is obtained in advance from Seller. This warranty does not apply to filter bags. This warranty will not be in effect where payment is overdue until such time that the equipment is paid for in full.



# GRIFFIN FILTERS

**(B) Limited Patent Warranty Respecting Equipment Manufactured by Seller.** Seller shall defend, at its expense, any suit or proceeding brought against Buyer which asserts any claim that any Equipment manufactured by Seller infringes any United States patent which was issued as of the date of the Proposal and Quotation, and Seller shall pay any damages and costs awarded therein against Buyer up to, but not to exceed, the aggregate amount of the sale price of the infringing Equipment theretofore paid by Buyer to Seller; provided, however, Buyer must give Seller written notice of any such claim within 10 days after Buyer is notified thereof; and provided further that Buyer must thereafter fully cooperate with Seller and give Seller all authority, information and assistance as Buyer is able to give in order to allow Seller to conduct such defense effectively and efficiently. If the use of any of the Equipment is enjoined as a result of any such suit, Seller shall, at its option and at its expense, procure for Buyer the right to use such Equipment, or modify the infringing Equipment so that it no longer infringes any United States patent, or replace the infringing Equipment with non-infringing Equipment, or refund the portion of the sale price attributable to the infringing Equipment.

**(C) Equipment Not Manufactured by Seller.** All Equipment which is not manufactured by Seller is sold AS-IS and carries only such warranties as are given by the manufacturer thereof (if any), which warranties (if any) are, to the extent permitted by their terms, hereby assigned by Seller to Buyer without recourse against Seller.

7. **LIMITATION OF WARRANTIES, REMEDIES AND OBLIGATIONS.** EXCEPT AS OTHERWISE EXPRESSLY PROVIDED HEREIN, THE EQUIPMENT IS BEING SOLD AS-IS, AND SELLER MAKES NO WARRANTIES OF ANY NATURE WHATSOEVER WITH RESPECT TO THE EQUIPMENT, ORAL OR WRITTEN, EXPRESS OR IMPLIED (INCLUDING, BUT NOT LIMITED TO, THOSE OF MERCHANTABILITY AND FITNESS OF USE FOR A PARTICULAR PURPOSE); AND SELLER HEREBY DISCLAIMS ANY WARRANTY NOT EXPRESSLY SET FORTH HEREIN. SELLER'S ONLY OBLIGATIONS FOR BREACH OF WARRANTY ARE AS SET FORTH HEREIN. SELLER WILL NOT BE LIABLE FOR ANY SPECIAL, INDIRECT, INCIDENTAL OR CONSEQUENTIAL DAMAGES OF ANY NATURE ARISING IN CONNECTION WITH THE EQUIPMENT, OR IN CONNECTION WITH SELLER'S PERFORMANCE OR BREACH OF ITS OBLIGATIONS HEREUNDER, REGARDLESS OF WHETHER BASED IN CONTRACT OR IN TORT, (INCLUDING, BUT NOT LIMITED TO, LOSS OF PROFITS, PLANT DOWN TIME, LOSS OF USE OF THE EQUIPMENT, AND CLAIMS, SUITS AND DAMAGES OF THIRD PERSONS, EXCEPT FOR U.S. PATENT INFRINGEMENT CLAIMS TO THE EXTENT PROVIDED IN CLAUSE (B) OF PARAGRAPH 6 ABOVE). IN NO EVENT WILL SELLER'S LIABILITY FOR PERFORMANCE OR BREACH OF ANY OF ITS OBLIGATIONS HEREUNDER EXCEED THE AMOUNT OF THE SALE PRICE THERETOFORE PAID BY BUYER TO SELLER. SELLER NEITHER ASSUMES NOR AUTHORIZES ANYONE TO ASSUME FOR IT ANY OTHER OBLIGATION OR LIABILITY OF ANY NATURE WHATSOEVER OR TO MAKE ANY ADDITIONAL REPRESENTATION OR WARRANTY NOT HEREIN CONTAINED RESPECTING THE EQUIPMENT OR SELLER'S OBLIGATIONS. By way of illustration, and not in limitation of the foregoing, no communication, representation or statement made by any sales agent or representative of Seller respecting the performance or operation of the Equipment, or otherwise, is binding upon Seller (the sole and exclusive warranties, representations and obligations of Seller being set forth herein). Further, Seller makes no representation or warranty that the Equipment complies with, or that it will perform or operate in accordance with, the requirements of any law, code, statute, regulation, rule or ordinance of any federal, state, local or other governmental authority (including, but not limited to, any pollution control agency). Seller neither undertakes nor has any obligation to obtain permits, licenses or approvals from any such governmental authority or agency concerning the Equipment or concerning the installation, operation or use thereof. Only such safety devices as are specified in the Proposal and Quotation will be furnished by Seller to Buyer. Buyer shall, at its expense, obtain and install all other safety devices required or desirable due to the nature of the Equipment or due to Buyer's operation of the Equipment. Seller hereby disclaims, and Buyer hereby releases Seller from, all liability arising out of the improper use of the Equipment or from the absence of proper safety devices respecting the Equipment. In no event will Seller be liable for any claim, loss, damage or expense arising out of the sole or contributory negligence of Buyer, its employees, agents, engineers, architects, or other contractors, and Buyer shall indemnify, defend and save Seller harmless therefrom (including, but not limited to, payment of Seller's reasonable attorneys' fees).
8. **PERFORMANCE LEVELS GUARANTY AND ACCEPTANCE TESTS.** In the event that the Equipment and/or Services Quotation page specifies that the provisions of the Performance Levels Guaranty and Acceptance Tests are applicable and the same are included as a part of the Proposal and Quotation, but only in such event, then Seller shall perform all of the additional obligations set forth therein. If the provisions of the Performance Levels Guaranty and Acceptance Tests are applicable, then wherever possible the provisions of these Standard Conditions of Sale are to be construed so as to be consistent with the provisions thereof; but in the event of any irreconcilable inconsistencies, the provisions of the Performance Levels Guaranty and Acceptance Tests will always prevail, govern and control.
9. **FORCE MAJEURE RESPECTING DELIVERIES BY SELLER.** All deliveries by Seller are contingent upon Seller's receiving necessary materials, parts, and components for its manufacture, assembly or supply of the Equipment to Buyer; and Seller's deliveries to Buyer may be delayed, reduced or canceled to the extent affected by delay, reduction or cancellation of shipments thereof from Seller's suppliers. Seller will not be liable for any default, delay, reduction or failure in delivery attributable thereto or attributable to strikes, lock-outs, disputes or disagreements resulting in labor stoppages, plant shutdowns or slowdowns at the facilities of Seller or elsewhere, government regulations, embargo, lack or failure of shipping facilities, military service, war, delays by carriers, casualties, fires, earthquakes, floods, storms, explosions, epidemics, civil commotion or disturbances, acts of God or any other causes or conditions, whether similar or dissimilar to those enumerated, beyond the reasonable control and without the negligence of the Seller. In such circumstances, the time for delivery by Seller will automatically be extended for the period of time Seller is delayed as a result thereof.
10. **MISCELLANEOUS.** All rights and remedies of Seller, whether provided for herein, or conferred by law, or in equity, or by statute, or otherwise are cumulative and not alternative, and can be enforced successively or concurrently. This Agreement cannot be amended except by a subsequent writing signed by Seller. Seller will not be deemed to have waived any of its rights or remedies hereunder unless such waiver is in writing and signed by Seller. No delay or omission by Seller in exercising any of its rights or remedies is to be deemed





# GRIFFIN FILTERS

to be a waiver thereof, and a waiver in writing on one occasion will be effective only in that specific instance and only for the precise purpose for which given. All communications hereunder must be in writing and are to be deemed to have been duly given and to be effective upon delivery to the party to whom directed. Communications that are sent by U.S. mail, first class, certified, return receipt requested, postage prepaid, are to be deemed to have been delivered 3 days after being so posted. None of Buyer's obligations hereunder may be assigned or delegated without the prior written consent of Seller. All of the provisions hereof will be binding upon and will inure to the benefit of both parties, and their respective successors and permitted assigns. Each of the provisions hereof is severable from each of the others; and if any provision hereof is prohibited or unenforceable under applicable law, such provision will be ineffective only to the extent of such prohibition or unenforceability without invalidating the remainder thereof or the remaining provisions hereof. The captions herein are for convenience of reference only and are not to be used in construing the provisions hereof. The Proposal and Quotation is made, and the contract contemplated hereby is to be substantially performed, in the State of New York, and all of the provisions hereof are in all respects (including, but not limited to, all matters of construction, interpretation, validity, enforcement, performance and the consequences of breach) to be construed in accordance with and governed by the internal laws (excluding all conflict of law rules) of that State (including, but not limited to, the Uniform Commercial Code of New York), as from time to time amended and in effect, and the applicable internal federal laws of the United States of America, as from time to time amended and in effect.

